



G-Mouse GPS User Manual

GPS GM210

PS-2 Connector

USB Connector

Version 1.01 2007 / 04 / 20

INDEX

1	OVERVIEW	3
2	PRODUCT FEATURE.....	3
3	SPECIFICATION	4
4	HARDWARE	5
4.1.	DIMENSION	5
4.2.	OUTPUT TERMINAL AND DEFINITION	6
4.3.	USB Driver.....	8
5.	SOFTWARE DATA	9
5.1.	NMEA OUTPUT MESSAGE.....	9
5.2.	GLOBAL POSITIONING SYSTEM FIX DATA (GGA)	9
5.3.	GEOGRAPHIC POSITION WITH LATITUDE/LONGITUDE(GLL).....	10
5.4.	GNSS DOP AND ACTIVE SATELLITES (GSA).....	11
5.5.	GNSS SATELLITES IN VIEW (GSV)	12
5.6.	RECOMMENDED MINIMUM SPECIFIC GNSS DATA (RMC)	13
5.7.	COURSE OVER GROUND AND GROUND SPEED (VTG)	14
5.8.	RTCM RECEIVED DATA	14
6.	WARRANTY.....	15



1 OVERVIEW

Congratulation on your purchase of ELS, which manufacture and provide various GPS applications. ELS's **GM210** GPS Receiver provides you various applications such as car navigation, marine navigation, mapping, surveying, security, agriculture and so on. It communicates with device (such as PocketPC or notebook) via compatible dual-channel through RS-232 or TTL and saves satellite data by built-in backup memory. Low power consumption technology enables **GM210** and your device to save more operating power. Furthermore, **GM210** can track up to 20 satellites at a time, re-acquire satellite signals in 100ms and update position data every second. Trickle-Power allows the unit to operate a fraction of the time, and Push-to-Fix permits user to have a quicker position fix even though the receiver stays off.

2 PRODUCT FEATURE

- SiRF Star III Low Power Consumption Chipset
- Integrated ARM7TDMI CPU
- Cold Start : within 50 seconds
- 12 parallel satellite-tracking channels for fast acquisition and reacquisition
- A rechargeable battery sustains internal clock and memory. The battery is recharged during normal operation
- Support NMEA 0183 V2.2 command
- Differential capability utilizes real-time RTCM corrections producing 1-5 meter position accuracy.
- User initialization is not required.
- Dual communication channels and user selectable baud rates allow maximum interface capability and flexibility.
- Optional communication levels, RS-232 and TTL meet ordinary application and new fashions of connecting PDA with TTL or RS-232 output.
- Built-in WAAS Demodulator.
- LED display status: The LED provides users visible positioning status. LED "BLINKING" when power connected and "ON" when GGM309U got positioned.
- FLASH base program memory



3 SPECIFICATION

Key Feture

Frequency	L1, 1575.42 MHz
C/A Code	1.023 MHz chip rate
Channels	12
Sensitivity	Acquisition : -144~ -149 dBm Tracking : -155~ -160dBm

Non DGPS (Differential GPS)

Position Horizontal	5 to 25 meter CEP, without SA
Velocity	0.1 meter/second, without SA
Time	1 microsecond synchronized GPS time

DGPS (Differential GPS)

Position Horizontal	1 to 5 meter, typical
Velocity	0.05 meter/second, typical
EGNOS/WAAS	< 2.2 m, horizontal 95% of time
Datum	WGS-84

Performance

Hot start	2 sec., average
Warm start	38 sec., average
Cold start	50 sec., average
Reacquisition	0.1 sec. average
GPS Protocol	Default: NMEA 0183 V2.2 (Secondary: SiRF binary)
GPS Output Data	SiRF binary >> position, velocity, altitude, status and control ; NMEA 0183 protocol, and supports command: GGA, GSA, GSV, RMC, VTG, GLL (VTG and GLL are optional)
GPS transfer rate	Software command setting (Default : 4800,n,8,1 for NMEA)
Acceleration Limit	Less than 4g
Altitude Limit	18,000 meters (60,000 feet) ma
Velocity Limit	515 meters/sec. (1,000 knots) max.
Jerk Limit	20 meters/second, max
Operating	-40°C to +85°C(internal temperature).
Storage	-45°C to +100°C
Input Voltage	+4.75 ~ 5.5 VDC without accessories.
Power consumption	<80mA at 4.5- 5.5V input
Dimension	1.69" x 1.47" x 0.66" (43mm x 37.5mm x 16.99mm)
Cable Length	60" (1500mm)



4 HARDWARE

4.1. Dimension

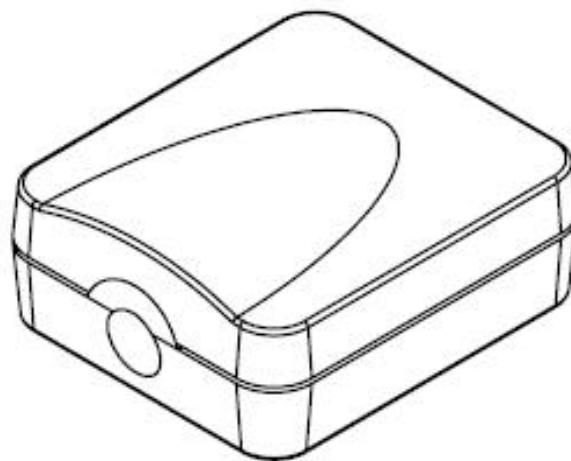
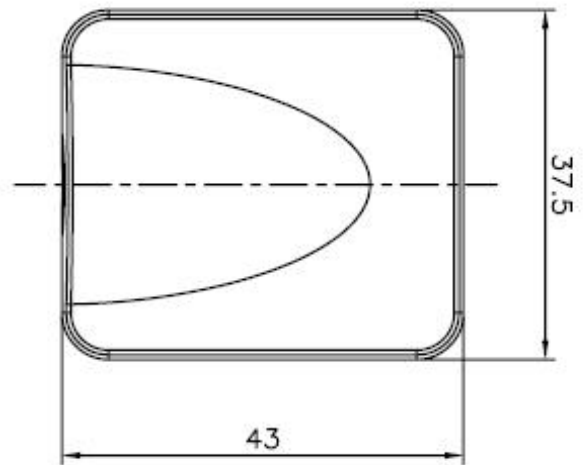
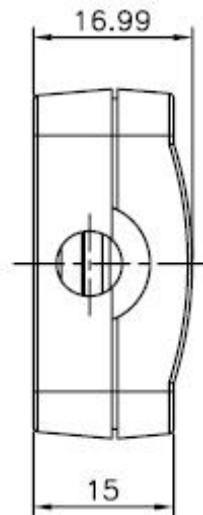



4.2. Output terminal and definition

- Output terminal: PS-2 female
- Pin Definition:

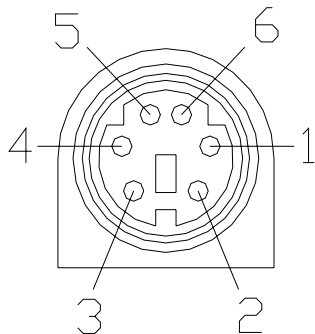

PS-2 female connector

Pin	Signal	
	RS-232	RS-232+TTL
1	TX	TX (RS232)
2	+5VDC	+5VDC
3	NC	TX (TTL)
4	Ground	Ground
5	DGPS IN	RX (TTL)
6	RX	RX (RS232)



- Output terminal:: USB connector
- Pin definition:

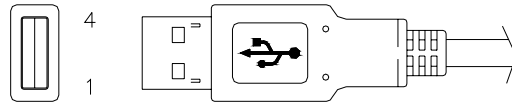

Pin	Signal Name
1	+5V
2	TXD
3	RXD
4	Ground



4.3. USB Driver

➤ System Requirement

IBM, Pentium or above and other compatible PC; 16 MB and above memory; Windows

98/Me/2000; VGA Graphic Adapter.

➤ Installation

1. Copy entire 【GM210 USB_Driver】 folder from CD to hard disk.
2. Connect GGM308 USB connector to computer. While the computer automatically starts the installation program, please direct the driver to the 【GM210 USB】 folder.
3. After the installation is complete, go to 【Device Manager】 and select 【Ports (COM & LPT)】 to verify if a virtual COM port 【USB to Serial Port】 was created.

※Notice: Verify the COM port # to start using your own navigating software.

1. Click <Start> menu, select <Settings>, then enter <Control Panel>.
2. After entering <Control Panel>, select <System>.
3. Select <Device Manager>
4. Find the <Connect port> and check the Virtual COM Port, which was created by the USB driver,

Please note that the Virtual COM Port number might be different from every computer. Before using navigating software, please confirm the COM Port number created by your computer and provided by your navigation software. Otherwise, the navigating software won't receive the satellite signal, because of the un-match COM Port setting.



5. SOFTWARE DATA

- NMEA 0183 V2.2 Protocol
- Use RS-232 interface : 4800 bps, 8 bit data, 1 stop bit and no parity.

5.1. NMEA Output Message

Table 5-1 NMEA-0183 Output Messages

NMEA Record	Description
GPGGA	Global positioning system fixed data
GPGLL	Geographic position: latitude/longitude
GPGSA	GNSS DOP and active satellites
GPGSV	GNSS satellites in view
GPRMC	Recommended minimum specific GNSS data
GPVTG	Course over ground and ground speed

5.2. Global Positioning System Fix Data (GGA)

Table 5-2 contains the values for the following example

\$GPGGA,161229.487,3723.2475,N,12158.3416,W,1,07,1.0,9.0,M, , , ,0000*18

Table 5-2 GGA Data Format

Name	Example	Units	Description
Message ID	\$GPGGA		GGA protocol header
UTC Time	161229.487		hhmmss.sss
Latitude	3723.2475		ddmm.mmmm
N/S Indicator	N		N=north or S=south
Longitude	12158.3416		dddmm.mmmm
E/W Indicator	W		E=east or W=west
Position Fix Indicator	1		See Table 5-3
Satellites Used	07		Range 0 to 12
HDOP	1.0		Horizontal Dilution of Precision
MSL Altitude	9.0	Meters	



Table 5-2 GGA Data Format-continue

Name	Example	Units	Description
Units	M	Meters	
Geoid Separation		Meters	
Units	M	Meters	
Age of Diff. Corr.		second	Null fields when DGPS is not used
Diff. Ref. Station ID	0000		
Checksum	*18		
<CR> <LF>			End of message termination

Table 5-3 Position Fix Indicator

Value	Description
0	0 Fix not available or invalid
1	GPS SPS Mode, fix valid
2	Differential GPS, SPS Mode, fix valid
3	GPS PPS Mode, fix valid

5.3. Geographic Position with Latitude/Longitude(GLL)

Table 5-3 contains the values for the following example.

\$GPGLL,3723.2475,N,12158.3416,W,161229.487,A*2C

Table 5-4 GLL Data Format

Name	Example	Units	Description
Message ID	\$GPGLL		GLL protocol header
Latitude	3723.2475		ddmm.mmmm
N/S Indicator	N		N/S Indicator N N=north or S=south
Longitude	12158.3416		dddmm.mmmm
E/W Indicator	W		E=east or W=west
UTC Position	161229.487		hhmmss.sss
Status	A		A=data valid or V=data not valid
Checksum	*2C		
<CR> <LF>			End of message termination



5.4. GNSS DOP and Active Satellites (GSA)

Table 5-4 contains the values for the following example.

\$GPGSA,A,3,07,02,26,27,09,04,15, , , , ,1.8,1.0,1.5*33

Table 5-5 GSA Data Format

Name	Example	Units	Description
Message ID	\$GPGSA		GSA protocol header
Mode 1	A		See Table 5-6
Mode 2	3		See Table 5-7
Satellite Used(1)	07		Sv on Channel 1
Satellite Used(1)	02		Sv on Channel 2
Satellite Used			Sv on Channel 12
PDOP	1.8		Position Dilution of Precision
HDOP	1.0		Horizontal Dilution of Precision
VDOP	1.5		Vertical Dilution of Precision
Checksum	*33		
<CR> <LF>			End of message termination

NOTE: Satellite used in solution.

Table 5-6 Mode 1

Value	Description
M	Manual—forced to operate in 2D or 3D mode
A	2DAutomatic—allowed to automatically switch 2D/3D

Table 5-7 Mode 2

Value	Description
1	Fix Not Available
2	2D
3	3D



5.5. GNSS Satellites in View (GSV)

Table 5-8 contains the values for the following example

\$GPGSV,2,1,07,07,79,048,42,02,51,062,43,26,36,256,42,27,27,138,42*71

\$GPGSV,2,2,07,09,23,313,42,04,19,159,41,15,12,041,42*41

Table 5-8 GSV Data Format

Name	Example	Units	Description
Message ID	\$GPGSV		GSV protocol header
Number of Messages	2		Range 1 to 3
Message Number	1		Range 1 to 3
Satellites in View	07		Range 1 to 12
Satellite ID	07		Channel 1 (Range 1 to 32)
Elevation	79	degrees	Channel 1 (Maximum 90)
Azimuth	048	degrees	Channel 1 (True, Range 0 to 359)
SNR (C/No)	42	dBHz	Range 0 to 99, null when not tracking
Satellite ID	27		Channel 4 (Range 1 to 32)
Elevation	27	degrees	Channel 4 (Maximum 90)
Azimuth	138	degrees	Channel 4 (True, Range 0 to 359)
SNR (C/No)	42	dBHz	Range 0 to 99, null when not tracking
Checksum	*71		
<CR> <LF>			End of message termination

NOTE: Items <4>,<5>,<6> and <7> repeat for each satellite in view to a maximum of four (4) satellites per sentence. Additional satellites in view information must be sent in subsequent sentences. These fields will be null if unused.



5.6. Recommended Minimum Specific GNSS Data (RMC)

Table 5-9 contains the values for the following example.

\$GPRMC,161229.487,A,3723.2475,N,12158.3416,W,0.13,309.62,120598, ,*10

Table 5-9 RMC Data Format

Name	Example	Units	Description
Message ID	\$GPRMC		RMC protocol header
UTC Time	161229.487		hhmmss.sss
Status	A		A=data valid or V=data not valid
Latitude	3723.2475		ddmm.mmmm
N/S Indicator	N		N=north or S=south
Longitude	12158.3416		dddmm.mmmm
E/W Indicator	W		E=east or W=west
Speed Over Ground	0.13	knots	
Course Over Ground	309.62	degrees	True
Date	120598		ddmmyy
Magnetic Variation(1)		degrees	E=east or W=west
Checksum	*10		
<CR> <LF>			End of message termination

NOTE: SiRF Technology Inc. does not support magnetic declination. All “course over ground” data are geodetic WGS84 directions.



5.7. Course Over Ground and Ground Speed (VTG)

Table 5-10 contains the values for the following example.

\$GPVTG,309.62,T, ,M,0.13,N,0.2,K*6E

Table 5-10 VTG Data Format

Name	Example	Units	Description
Message ID	\$GPVTG		VTG protocol header
Course	309.62	degrees	Measured heading
Reference	T		True
Course		degrees	Measured heading
Reference	M		Magnetic(1)
Speed	0.13	knots	Measured horizontal speed
Units	N		Knots
Speed	0.2	km/hr	Measured horizontal speed
Units	K		Kilometers per hour
Checksum	*6E		
<CR> <LF>			End of message termination

NOTE: SiRF Technology Inc. does not support magnetic declination. All "course over ground" data are geodetic WGS84 directions.

5.8. RTCM Received Data

The default communication parameters for DGPS Input are 4800 baud, 8 data bits, stop bit, and no parity. Position accuracy of less than 5 meters can be achieved with the **GM-210** by using Differential GPS (DGPS) real-time pseudo-range correction data in RTCM SC-104 format, with message types 1, 2 or 9. As using DGPS receiver with different communication parameters, **GM-210** may decode the data correctly to generate accurate messages and save them in battery-back SRAM for later computing.



6. Warranty

A) Device: E Li Shin warrants to the original end user (“Customer”) that new E Li Shin branded products will be free from defects in workmanship and materials, under normal use, for one year if you are a purchaser in North America, Central America, and South America; 2 years if you are a purchaser in a EU member state that has enacted into national law the EU Directive on Consumer Guarantees (99/44/EC) from the original purchase date. At the time of service, the owner will need to be able to provide evidence of date and place of purchase and serial number.

B) Exclusions: This warranty excludes (1) physical damage to the surface of the product; (2) damage caused by misuse, neglect, improper installation or testing, unauthorized attempts to open, repair, or modify the product, or any other cause beyond the range of the intended use; (3) damage caused by accident, fire, power changes, other hazards, or acts of God; or (4) use of the product with any non-E Li Shin device or service if such device or service caused the problem.

Any third party products, including software, included with E Li Shin products are not covered by this E Li Shin warranty and E Li Shin makes no representations or warranties on behalf of such third parties. Any warranty on such products is from the supplier or licensor of the product.

C) Exclusive remedies: Should a covered defect occur during the warranty period and you notify E Li Shin, your sole and exclusive remedy shall be, at E Li Shin’s sole option and expense, to repair or replace the product. If E Li Shin cannot reasonably repair nor replace then E Li Shin may, in its sole discretion, refund the purchase price paid for the product. Replacement products or parts may be new or reconditioned or comparable versions of the defective item.

D) Obtaining warranty service: Dated proof of original purchase will be required. Products or parts shipped by Customer to E Li Shin must be sent postage-paid and packaged appropriately for safe shipment. E Li Shin is not responsible for Customer products received without a warranty service authorization and may be rejected. Repaired or replacement products become the property of E Li Shin.

WARRANTIES EXCLUSIVE: THE FOREGOING WARRANTIES AND REMEDIES ARE EXCLUSIVE AND IN LIEU OF ALL OTHER WARRANTIES, EXPRESS OF IMPLIED, INCLUDING WARRANTIES OF MERCHANTABILITY, FITNESS FOR A PARTICULAR PURPOSE, CORRESPONDENCE WITH DESCRIPTION, AND NON-INFRINGEMENT, ALL OF WHICH EXPRESSLY DISCLAIMED.

LIMITATION OF LIABILITY: NEITHER AEROST NOR ITS SUPPLIERS SHALL BE LIABLE FOR INCIDENTAL, CONSEQUENTIAL, INDIRECT, SPECIAL, OR PUNITIVE DAMAGES OF ANY KIND, LOSS OF INFORMATION OR DATA, OR OTHER FINANCIAL LOSS ARISING OUT OF OR IN CONNECTION WITH THE SALE OR USE OF THIS PRODUCTS, WHETHER BASED IN CONTRACT, TORT (INCLUDING NEGLIGENCE) OR ANY OTHER THEORY, EVEN IF ALTINA HAS BEEN ADVISED OF THE POSSIBILITY OF SUCH



DAMAGES. AEROST'S ENTIRE LIABILITY SHALL BE LIMITED TO REPLACEMENT, REPAIR, OR REFUND OF THE PURCHASE PRICE PAID, AT AEROST'S OPTION.